

SEZIONE A-A

USCITA ARIA REFRIGERATA
TREADED AIR DISCHARGE
ZULUFTAUSGANG
SORTIE AIR GLACEE
SALIDA AIRE ENFRIDA

	I	GB	D	F	E
ICW 1-2 Ø 1" 1/2 G	INGRESSO ACQUA REFRIGERATA	CHILLER WATER INLET	KALTWASSEREINGANG	ENTREE EAU GLACEE	ENTRADA AGUA ENFRIDA
UCW 1-2 Ø 1" 1/2 G	USCITA ACQUA REFRIGERATA	CHILLER WATER OUTLET	KALTWASSERAUSSGANG	SORTIE EAU GLACEE	SALIDA AGUA ENFRIDA
IHW Ø 1 1/4" G	INGRESSO ACQUA CALDA	HOT WATER INLET	WARMWASSEREINGANG	ENTREE EAU CHAUDE	ENTRADA AGUA CALIENTE
UHW Ø 1 1/4" G	USCITA ACQUA CALDA	HOT WATER OUTLET	WARMWASSERAUSGANG	SORTIE EAU CHAUDE	SALIDA AGUA CALIENTE
IP a-b	INGRESSO CAVO DI ALIMENTAZIONE	POWER SUPPLY CABLE INLET	SPEISEKABELEINGANG	ENTREE CABLAGE D'ALIMENTATION	ENTREE CABLAGE ALIMENTATION
IS	INGRESSO USCITA SEGNALI	SIGNALS INLET / OUTLET	EINGANG / AUSGANG SIGNALE	ENTREE / SORTIE SIGNALES	ENTRADA / SALIDA SINIALIZACIONES
IR	INGRESSO RETE	NETWORK INLET	NETWORKEINGANG	ENTREE RESEAU	ENTRADA RED
F Ø 6	INGRESSO ACQUA UMIDIFICATORE	HUMIDIFIER WATER INLET	WASSEREINGANG BEFEUCHTER	ENTREE EAU HUMIDIFICATEUR	ENTRADA AGUA HUMECTADOR
C-D Ø 32	SCARICO ACQUA UMIDIFICATORE E/O CONDENSA	HUMIDIFIER / CONDENSATE DRAIN CONNECTION	KONDENSAT - BZB. BEFEUCHTERAB - FLUSS	DECHARGE EAU HUMIDIFICATEUR ET/OU CONDENSEUR	DESCARGA AGUA HUMECTADOR Y/O CONDENSADOR
AR Ø 100	INGRESSO ARIA DI RINNOVO	FRESH AIR INLET	FRISHLUFTEINGANG	ENTREE AIR NEUF	ENTRADA AIRE DE RENOVO

ICW2 - UCW2 = SOLO PER VERSIONE DUAL COIL
ONLY VERSION DUAL COIL
NUR VERSION DUAL COIL
SEULEMENT VARIATION DUAL COIL
SOLO VERSION DUAL COIL

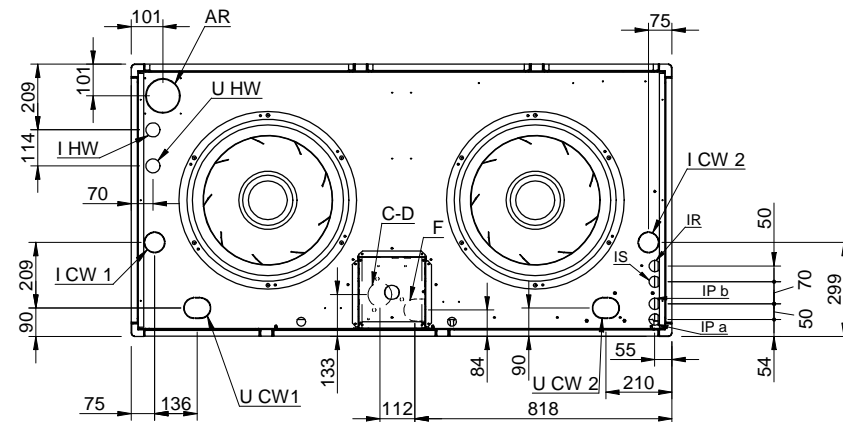

B Aggiunto uscite per Dual Coil		M.Chiodetto	06/05/08		
REV.	Descrizione - Description	Disegnatore - Draftsman	Data - Date	Visto - Checked by	n' Com.
Materiale Material		Trattamento Treatment		Rif. Com.	
		Denominazione-Denomination DISEGNO DI INSTALLAZIONE INSTALLATION DRAWING		Series TDC Modello-Model 1700	
Scala-scale	QUOTE SENZA INDICAZIONE DI TOLLERANZA	Dis.-Draftsman A.Miotto	Foglio Sheet N. 1/1	Disegno-Drawing DICI898X2A	
	Grado di precisione medio UNI EN 22768-1(1996)	Visto-Checked by	Data-Date 19/10/2005		REV. B